

THB

Perforated Ceiling Diffuser

20/THB/3500/0606/EN



- Horizontal air supply, suitable also for exhaust
- Installation either directly to ductwork or balancing plenum
- Detachable front panel enables the cleaning of the diffuser and ductwork
- Deflector panels for direction of flow pattern in 1, 2, 3 or 4 directions
- Circular duct connection with rubber gasket

Accessories

- Balancing plenum with measurement and adjustment functions
- Installation panel for modular 600x600 mm ceiling

MATERIAL AND FINISHING

PART	MATERIAL	NOTE
Upper plate	Steel	
Front panel	Perforated steel	
Deflection panels	Steel	
Coupling sleeve with gasket	Galvanised steel	Gasket rubber compound
Installation panel	Steel	
Finishing	Epoxy-painted / White RAL 9010	Special colour available

QUICK SELECTION

qv	Pa	240	360	480	600	720	960	1200	1440	1680	1920	2400	3000	3600	4200	4800		
	l/s	20	30	40	50	60	80	100	120	140	160	200	250	300	350	400		
	m ³ /h	72	108	144	180	216	288	360	432	504	576	720	900	1080	1260	1440		
THB-100(R4)	LpA	16	25	34	43	51												
	ΔPst	4	8	14	22	32												
	ΔPtot	7	17	30	46	67												
	Ld	-	-	-	-	-												
	Lmin	-	0,5	0,5	0,7	1,1												
	L0.2	1,0	1,6	2,0	2,4	2,8												
THB-125(R4)	LpA		21	25	30	36	48											
	ΔPst		3	5	7	11	19											
	ΔPtot		6	11	17	25	44											
	Ld		-	-	-	-	-											
	Lmin		-	0,5	0,5	0,8	1,3											
	L0.2		1,4	1,8	2,2	2,6	3,2											
THB-160(R4)	LpA			20	23	26	33	40	48									
	ΔPst			3	4	6	12	18	26									
	ΔPtot			5	8	12	21	33	47									
	Ld			-	-	-	-	-	-									
	Lmin			-	0,5	0,5	1,0	1,4	1,9									
	L0.2			1,4	1,8	2,2	2,8	3,4	4									
THB-200(R4)	LpA						24	30	37	44	50							
	ΔPst						6	10	14	19	25							
	ΔPtot						10	16	23	31	40							
	Ld						2,6	3,0	3,4	3,6	4,0							
	Lmin						1,4	2,2	3,2	4,0	4,8							
	L0.2						2,8	3,6	4,2	5,0	5,8							
THB-250(R4)	LpA							24	27	32	36	46						
	ΔPst							6	8	11	15	23						
	ΔPtot							8	12	16	21	33						
	Ld							2,8	3,2	3,4	3,8	4,4						
	Lmin							2,0	2,8	3,6	4,2	5,8						
	L0.2							3,2	4,0	4,6	5,4	6,6						
THB-315(R4)	LpA								23	26	30	38	48					
	ΔPst								7	9	12	19	29					
	ΔPtot								8	11	14	23	35					
	Ld								2,6	2,8	3,2	3,6	4,2					
	Lmin								1,8	2,4	3,0	4,2	5,8					
	L0.2								3,2	3,6	4,2	5,2	6,6					
THB-400(R4)	LpA										23	29	35	42	48			
	ΔPst										7	11	16	22	29			
	ΔPtot										9	14	20	27	35			
	Ld										2,8	3,2	3,6	4,0	4,4			
	Lmin										3,0	4,2	5,4	6,6	7,8			
	L0.2										4,2	5,2	6,2	7,2	8,4			

LpA values presented with room attenuation 4 dB (red 10m² - sab). When using room attenuation 8 dB (red 25m² - sab):
LpA - 4dB.

Pa Supply air cooling capacity, W
LpA A-weighted sound pressure level, reduced by total equivalent absorption surface of 10m², dB(A) red 10m² - sab
ΔPst Static pressure drop, Pa

ΔPtot Total pressure drop, Pa
Ld Distance from the supply unit, at which air jet detaches from ceiling, m
Lmin Minimum distance between central lines of two supply units, m (V3 = 0,25m/s at 1.8m height)
L0.2 Isothermal throw length, m when residual velocity of supply air jet 0,2 m/s
Room temperature (Tr) = 24 °C
Supply air temperature (Ta) = 14 °C
Room height = 2,8 m



Function

- Air is supplied into the space through the side slots and front panel of the diffuser and mixed with the room air outside the diffuser
- Recommended maximum air temperature difference between supply and room air is 10 °C
- The throw pattern can be deflected in different (1, 2, 3 and 4) directions with the deflection panels

ACCESSORIES

ACCESSORY	CODE	DESCRIPTION
Balancing plenum	TRI	For balancing & equalising the airflow and attenuating the duct noise
Installation panel	IP	For 600x600 module ceiling installation, colour RAL 9010

DIMENSIONS

NS	W	W1	H	ØD
100	300	270	50	99
125	300	270	50	124
160	300	270	50	159
200	450	420	60	199
250	450	420	60	249
315	600	565	60	314
400	600	565	60	399

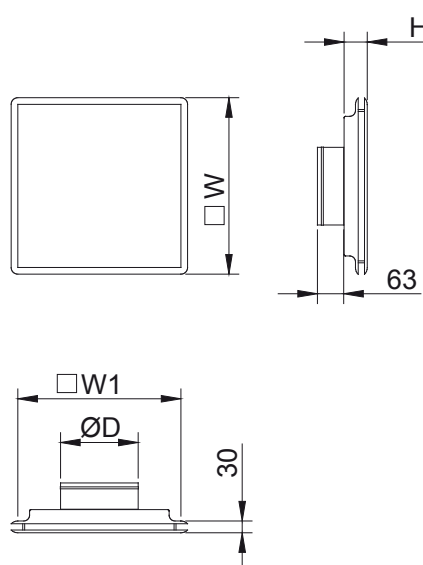

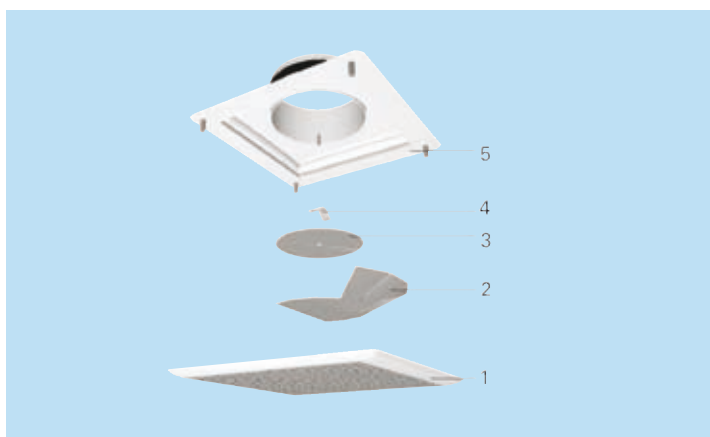

Installation

CODE DESCRIPTION

1	Front panel
2	Deflector panel
3	Deflector plate
4	Spring
5	Upper plate

The diffuser is connected either directly to the duct by screwing or riveting, or alternatively to the TRI balancing plenum. The desired flow pattern is selected during installation with the deflector panels, according to the installation manual.

The recommended minimum safety distance upstream of the diffuser is $3 \times D$.

In an exhaust application neither deflector panel nor deflector plate is used.

Installation with TRI

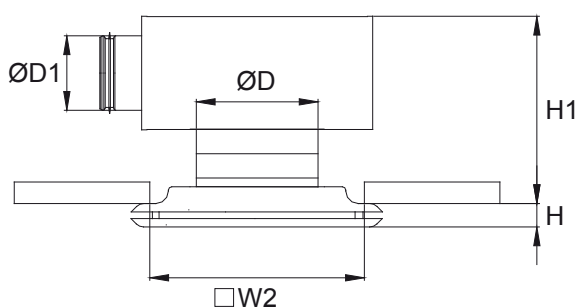

The collar of TRI plenum can be installed either internally in the plenum or externally onto the bottom of the plenum. The height of the unit for the external installation is presented in the table below. When

the collar is installed internally, the total height $H1$ is reduced by 60 mm.

The technical performance for the combination of supply air diffuser and TRI plenum is presented separately for the two different installations. See HIT Design software.

THB (ØD)	ØD1	TRI	W2	H	H1
100	100	TRI-100-100	105	50	220-250
125	100	TRI-100-125	130	50	220-250
125	125	TRI-125-125	130	50	250-280
160	100	TRI-100-160	165	50	220-250
160	125	TRI-125-160	165	50	250-280
160	160	TRI-160-160	165	50	290-320
200	125	TRI-125-200	205	60	250-280
200	160	TRI-160-200	205	60	290-320
200	200	TRI-200-200	205	60	340-370
250	125	TRI-125-250	255	60	250-280
250	160	TRI-160-250	255	60	290-320
250	200	TRI-200-250	255	60	340-370
250	250	TRI-250-250	255	60	403-433
315	200	TRI-200-315	320	60	340-370
315	250	TRI-250-315	320	60	403-433
315	315	TRI-315-315	320	60	450-480
400	200	TRI-200-400	405	60	340-370
400	250	TRI-250-400	405	60	403-433
400	315	TRI-315-400	405	60	450-480

Servicing

Open the front panel of the diffuser and clean the parts by wiping them with a damp cloth.

Push the front panel back into place so that the springs lock.

Option with balancing plenum

Open the front panel of the diffuser.

Remove the measurement and adjustment module by gently pulling the shaft (NB. not the control spindle or measurement tubes!).

Wipe the parts with a damp cloth, instead of immersing in water.

Remount the measurement and adjustment module by pushing in the shaft until the unit meets the stopper.

Push the front panel back into place so that the springs lock.

Adjustment

The THB itself has no means for airflow adjustment.

In order to enable airflow adjustment and measurement of airflow rate it is recommended to connect the diffuser to the TRI balancing plenum.

The supply flow rate is determined by using the measurement and adjustment module MSM.

Open the front plate and pass the tubes and control spindle through the side slot of the diffuser. Replace the front panel.

Measure the differential pressure with a manometer.

The flow rate is calculated using the formula below.

$$q_v = k \cdot \sqrt{\Delta p_m}$$

Adjust the airflow rate by rotating the control spindle until the desired setting is achieved. Lock the damper position with a screw.

Replace the tubes and spindle into the plenum and replace the diffuser front panel.

K-factor for installations with different safety distances (D= duct diameter)

TRI	>8XD	min 3XD
100	6.0	7.5
125	9.9	12.6
160	16.9	21.9
200	28.3	31.0
250	47.9	51.5
315	78.6	

Pressure drop, throw pattern and sound data

THB-100, THB-125, THB-160

4-way pattern



THB-200, THB-250, THB-315, THB-400

4-way pattern

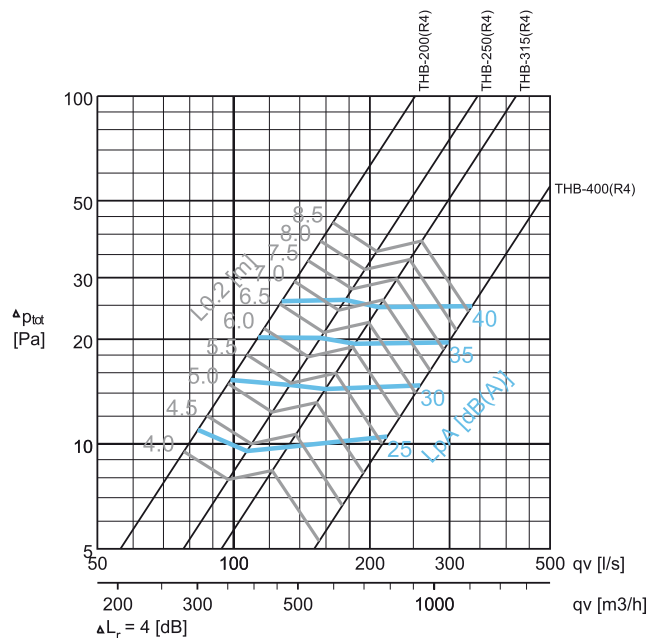
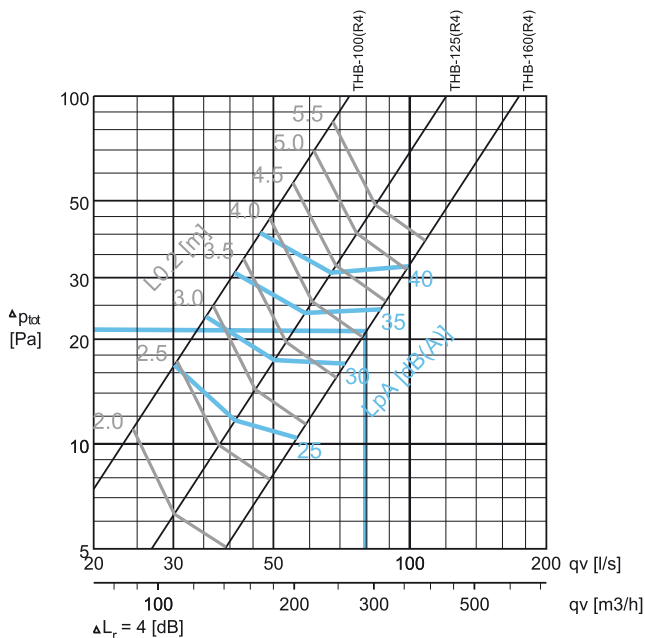

Selection example :

Requirements :	qv = 80 l/s	Selection : THB-160
	LpA ≤ 35 dB(A)	LpA = 33 dB(A)
	L0,2 ≤ 4,5 m	L0,2 = 4,1 m
	4-way pattern	ΔPtot = 21 Pa

SOUND LEVEL DATA

THB 4 way pattern	qv (l/s)	(m ³ /h)	ΔPst (Pa)	ΔPtot (Pa)	F (Hz)							LpA [dB(A)]	NR	NC
					63	125	250	500	1000	2000	4000			
THB-100(R4)	30	108	8	17	44	29	28	30	21	7	3	25	22	20
	35	126	11	23	45	33	32	34	29	17	3	30	26	25
	41	148	15	31	46	37	36	38	35	26	9	35	31	30
	47	169	19	40	46	40	40	42	41	34	15	40	37	36
THB-125(R4)	41	148	5	12	51	30	27	28	21	6	3	25	20	18
	50	180	7	17	51	35	32	33	29	18	3	30	25	24
	59	212	10	24	51	39	36	37	36	28	11	35	32	30
	67	241	13	31	52	43	40	40	41	36	19	40	37	36
THB-160(R4)	56	202	6	10	49	28	22	30	18	3	3	25	22	20
	72	259	9	17	51	36	30	34	28	15	3	30	26	24
	86	310	13	24	52	42	36	37	36	26	12	35	32	30
	99	356	18	32	53	47	41	40	41	34	21	40	37	36
THB-200(R4)	83	299	7	11	39	28	26	30	21	6	3	25	22	20
	98	353	9	15	42	33	31	34	29	16	3	30	26	25
	113	407	12	20	45	37	35	37	36	25	7	35	32	31
	128	461	16	26	47	41	39	40	42	33	13	40	38	37
THB-250(R4)	107	385	7	10	49	30	26	30	17	3	3	25	22	20
	133	479	10	15	51	36	32	34	28	16	3	30	26	24
	156	562	14	20	52	41	36	37	36	25	7	35	32	30
	176	634	18	26	53	44	40	40	42	33	13	40	38	37
THB-315(R4)	131	472	8	10	45	29	26	31	18	3	3	25	22	21
	159	572	12	14	47	35	32	35	28	15	3	30	27	25
	185	666	16	19	48	39	36	38	36	24	5	35	32	30
	209	752	20	25	49	43	39	40	42	32	10	40	38	37
THB-400(R4)	219	788	9	11	44	29	28	30	19	6	3	25	22	20
	259	932	12	15	47	35	33	34	28	17	3	30	26	25
	299	1076	16	20	49	40	38	38	35	26	8	35	31	30
	337	1213	21	25	50	44	41	41	41	33	15	40	37	36

LpA values presented with room attenuation 4 dB (red 10m² - sab). When using room attenuation 8 dB (red 25m² - sab): LpA - 4dB.
NR/NC noise criteria

Suggested Specifications

The diffuser shall be made of epoxy-painted steel with a white (RAL 9010) standard colour. Air shall be introduced into the space through the side slot and perforated front panel, ensuring a high mixing rate. Flow pattern of the diffuser shall be adjustable in 1, 2, 3 or 4-way directions by shaping the deflector.

Alternative 1; no balancing plenum

The diffuser shall have a spigot with integral gasket for connection to circular duct.

The diffuser shall have a detachable perforated front panel to provide access to the duct.

Alternative 2; option with balancing plenum

The diffuser shall be connected to a balancing plenum equipped with a measurement and adjustment module.

The diffuser shall have a detachable perforated front panel to provide access to the measurement and adjustment module in the plenum.

The balancing plenum shall have a spigot with integral gasket for airtight duct connection.

The balancing plenum shall comprise sound attenuation material made of polyester fibre with a washable surface.

Product code

THB-D

D = Diameter of duct connection
100, 125, 160, 200, 250, 315, 400

Specifics and accessories

CO = Colour

W	White
X	Special colour

Code example

THB-100, CO=W

Sub products

TRI	Plenum (Diffusers)
IP	Installation panel (595x595 mm)